

# Landing gears · OPTIMA

## Advantages at a glance

- Weight-optimised
- Economical
- Ideally suited for long-distance transport

## Technical Features

- Three plate positions (upper, lower, double)
- S foot with 125 mm drift
- Four different mounting heights

## Technical Specification

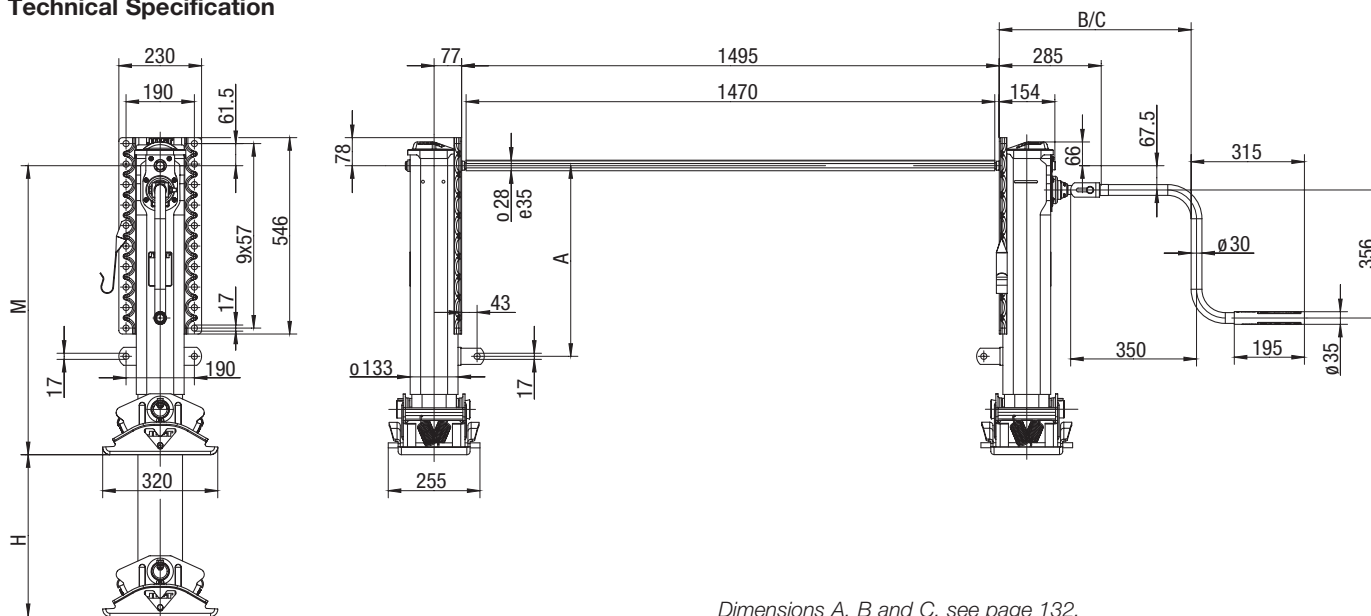

Dimensions A, B and C, see page 132.

## Selection table / Versions available

Order No.	M (mm)	H (mm)	A (mm)	Back plate
OPT850S-3	850	500	580	double
OPT800S-3	800	450	530	double
OPT750S-3*	750	400	–	double
OPT700S-3*	700	350	–	double

## Technical Data (per kit)

Characteristic	Value
Lifting capacity	24 t
Static load	50 t
Lift per turn of handle	
- Low gear	0,9 mm
- High gear	15,0 mm
Crank force at 16 t super imposed load	210 N

### Remark:

\* No bracing brackets are included in the delivery of mounting heights M = 750 and 700. These can be ordered separately.

Crank handles and connection shafts need to be ordered separately and are shipped unassembled.

Bracing brackets can be found on page 132.

## Cross-reference list

When converting the order number of L500 to the OPTIMA order number, only the position of the mounting height and the foot changes. All order numbers can be adapted in this way.

### Examples:

L500S850-1 replaced by OPT850S-1

L500S850-1L replaced by OPT850S-1L

L500S850-1R replaced by OPT850S-1R

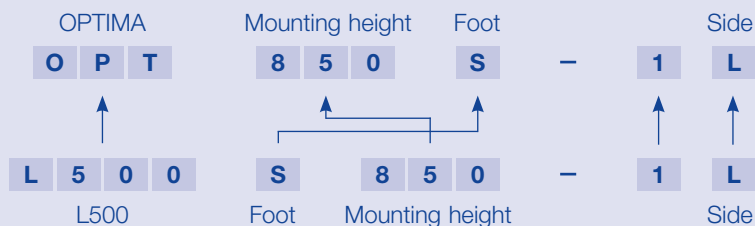

# OPTIMA

## Spare parts

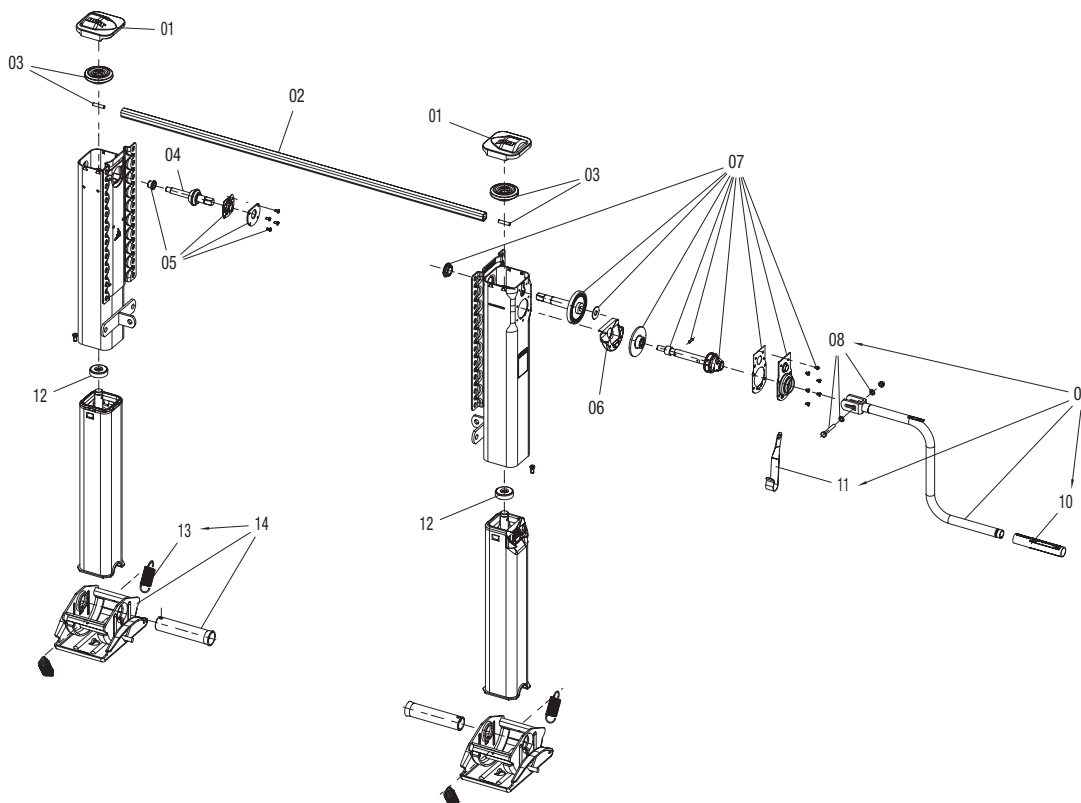

Item	Description	Remark	Order No.	per piece
01	Cover with bolts		JS E0046100	1
02	See individual components			1
03	Bevel gear with bolts		JS E0058600	2
04	Shaft		JS E0001500	1
05	Bearing	compl.	JS E0046200	1
06	Grease tank	compl.	JS E0002000	1
07	Drive		JS E0083700	1
08	Bolts with washers and nuts		JS E0043100	1
09	See individual components			1
10	Crank bushing		JS E0042700	1
11	Crank parking hook	for crank 350 mm (JS U01)	JS E0040200	1
11	Crank parking hook	for crank 415–480 mm (JS U02–JS U04)	JS E0040201	1
11	Crank parking hook	for crank 520 mm (JS U05)	JS E0040202	1
12	Axial bearing		JS E0066401	2
13	Tension spring for S foot		JS E0012900	4
14	S foot	compl., with 13	JS E0123400	2

## Individual components

Item	Description	Remark	Order No.	per kit	Item	Description	Remark	Order No.	per kit
02	Connection shaft 1340 mm		JS L01	1	09	Crank 350 mm w. parking hook	with 08, 10 + 11	JS U01	1
02	Connection shaft 1450 mm		JS L02	1	09	Crank 415 mm w. parking hook	with 08, 10 + 11	JS U02	1
02	Connection shaft 1470 mm		JS L02	1	09	Crank 450 mm w. parking hook	with 08, 10 + 11	JS U02	1
02	Connection shaft 1500 mm		JS L04	1	09	Crank 480 mm w. parking hook	with 08, 10 + 11	JS U04	1
02	Connection shaft 1505 mm		JS L05	1	09	Crank 520 mm w. parking hook	with 08, 10 + 11	JS U05	1
02	Connection shaft 1575 mm		JS L06	1					
02	Connection shaft 0905 mm		JS L07	1					
02	Connection shaft 0935 mm		JS L08	1					
02	Connection shaft 1700 mm		JS L09	1					
02	Connection shaft 1790 mm		JS L10	1					